

# TRUCKVACPRO

VACUUM CLEANING SYSTEM FOR PROFESSIONAL DRIVERS  
WWW.TRUCKVACPRO.COM 1-888-ROADVAC



- Installs under your sleeper bed
- Convenient cleaning anywhere on the road
- Over 450 powerful air watts
- 3 year motor warranty
- Lifetime canister warranty
- Made in the USA by a 48+ year central vacuum company
- Multiple accessories standard and options available

TruckVac Pro is a powerful interior cleaning system designed to fit under the sleeper bed storage area of your truck. No more waiting in line for coin-operated systems with weak suction! TruckVac Pro is easy to install and to use. Simply plug in the storable hose, add your required attachments and let its power work for you. Some sleepers require the canister power unit to be installed horizontally. Check with your sales representative or call for help configuring your most effective installation method.

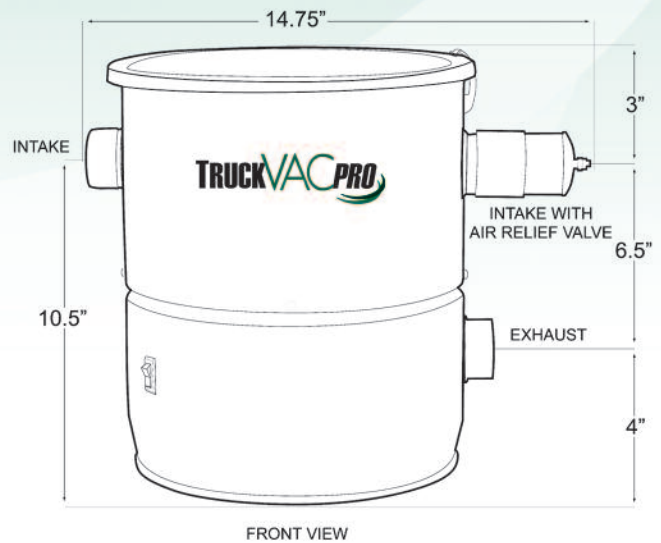
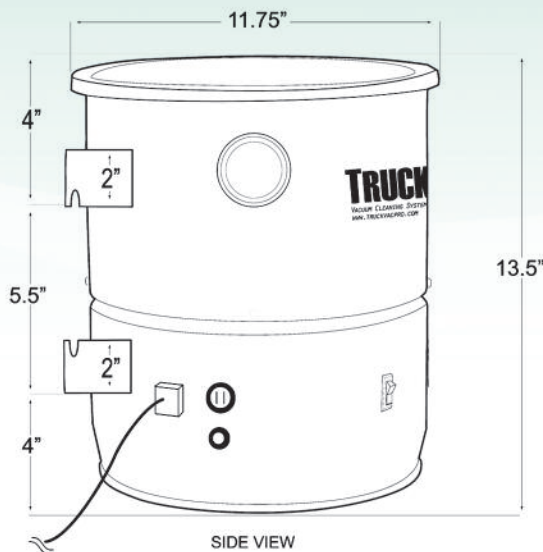

### PERFORMANCE

Sealed Vacuum.....	108"
CFM .....	119.5
Air Watts .....	453
Volts.....	120
Amperage .....	10.2

### FEATURES

- Motor:** One 1-stage motor producing highly effective air watts.
- Filtration:** Double filtration through microfilter bag and a foam filter.
- Construction:** Durable powder-coated all steel body. Lock-down lid.
- Overload:** Heat protection resettable mini-breaker.
- Warranty:** 3 years on motor and lifetime on manufacturing.
- Weight:** 12.5 pounds
- Accessories:** Standard accessories-12.5-foot hose, 18" wand, crevice tool, 6" upholstery tool, round dusting brush, mesh tool bag.
- Options:** Turbo handle, deluxe dusting brush, lint brush, various inlet door styles, pet grooming set and more. See web site for a complete list of available options.

### INSTALLATION

- Electrical:** 120V - 50/60Hz, 15 amp circuit. 2000 watt or greater inverter required or generator. 6' cord plugs into standard grounded receptacle.
- Mounting:** Vertical or horizontal mounting. Minimum space required is 13.5"Hx13.5"Dx19"W. Allow 8" minimum above unit to empty (simply raising sleeper bunk achieves this).
- Venting:** Venting to rear of cab recommended or have sleeper bed up during operation.
- Required:** Included air-relief valve must be installed in-line or on an intake neck.
- Installation accessories:** Two 2-foot PVC tubes, 90-degree short PVC elbow, PVC vacuum connector coupling, 5 feet of flex tubing, 8 feet of 20g wire, 3-in-1 inlet bracket, inlet cover plate, vent cover.